

The TITAN

A high performance manual or semi-automatic operated wet blast machine developed specifically for general purpose continuous production use offering...

- Single operation cleaning – grease, oil, burnt-on carbon, paint, grime, scale... all removed simultaneously
- Complete elimination of dust and heat during cleaning
- No component erosion or media impregnation – threads, bearing areas and other critical measurements maintained
- No toxic or harmful chemicals – no atmospheric or environmental pollution
- Capable of processing all types of materials
- Lower media and maintenance cost than conventional dry blasting



Capacity

Internal dimensions: 150 cm wide x 180 cm high x 175 cm deep with a 125cm diameter abrasive resistant turntable with a 750 kg load capacity. A wide range of component profiles and dimensions can be accepted. Mesh grids are mounted beneath the turntable to prevent components falling into the sump.

Visibility

Good visibility is achieved by a wide safety window with water spray, and pneumatic wiper, plus high-density fluorescent lighting. The special safety glass provides high strength and white, blast resistant, PVC curtains give excellent light reflectivity and visibility as well as protection to the internal operating area of the machine.

Ergonomics

The unit can be operated standing, or sitting or semi-automatically. The large diameter, heavy-duty electrically controlled revolving turntable aids heavy component handling. The process gun can be hand-held, or bracket mounted or semi-automated. A mains water rinse nozzle is provided.

Easy Loading

A right hand door, which is fitted

with a safety switch and cam-action locking handles, allows easy access.

Simple Control

Control of the pump and compressed air is by knee-operated switches in manual mode. Further air control is by an air pressure regulator and gauge incorporated into the airline. In semi-automatic mode control of the blast cycle is by PLC.

High Performance

This is achieved with the purpose-designed high volume pump and matching process gun. Both pump and process gun(s) are lined to give maximum protection against abrasive wear.

Versatility

The system can be used with a wide range of abrasives; glass beads, plastic, sodium bicarbonate, organic and other soft blast media.

Power Consumption

The pump is an 11 kW glandless system, capable of simultaneously running up to 12 process guns, if required, for the customer's application.

Compressed air consumption ranges from 1.13 to 1.7 m³/min (40-60 CFM) depending upon the speed and

intensity of blasting required. Where multiple process guns are required for the application, a higher nominal free air volume is needed.

GRP Construction

Sound attenuation of the glass fibre reinforced (GRP) plastic cabinet is nominally 85 db(A). The cabinet includes waste removal. Quality components ensure minimum maintenance.

Optional Equipment

Sump Overflow Tank: This is connected to the machine overflow to trap solids that might otherwise be carried to drains. A baffle retains floating contamination like oil and grease that can be periodically decanted off.

Closed Circuit System: Intended for installations where drainage is unavailable. Waste solids and floating contamination are removed whilst cleansed water is recirculated back to the machine.

Portable Wet Cyclone (PWC) Unit: A portable centrifugal separator, when connected into the media circuit, removes the media charge for maintenance or to change the media. The PWC is offered complete.

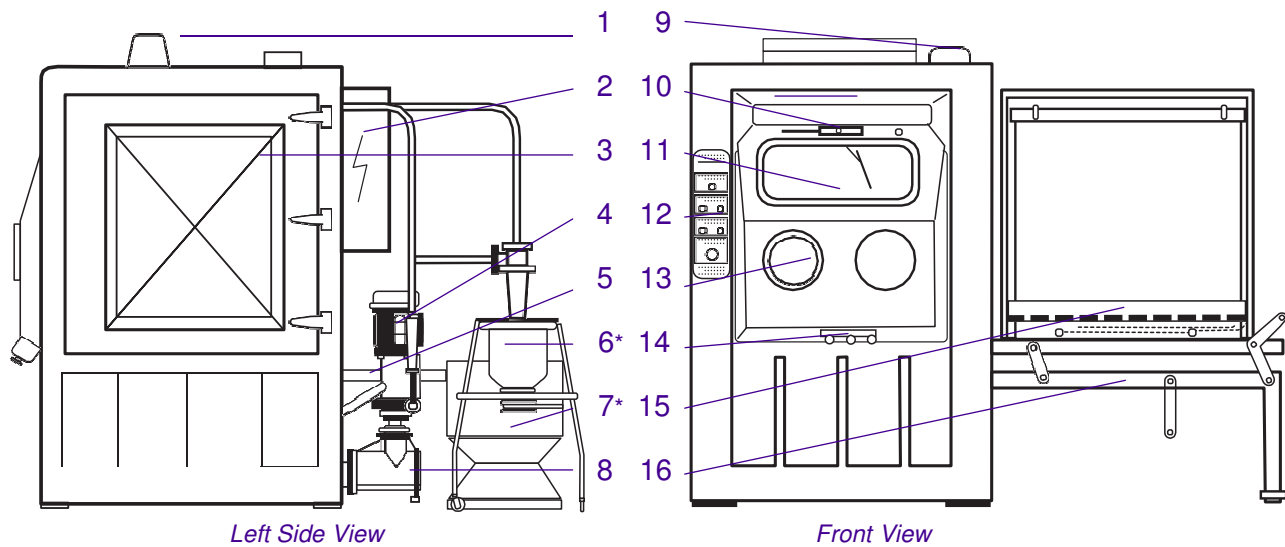

Left Side View

Front View

SPECIFICATIONS

External Dimensions

Height	252 cm	(99")
Depth (inc of pump unit)	212cm	(83")
Width (door closed)	150 cm	(59")
Width (door open)	275 cm	(108")
Loading height	96 cm	(38")
Working height at gloves	124 cm	(49")

Internal Dimensions

Height above turntable	108 cm	(43")
Depth (front to rear)	166 cm	(66")
Width	150 cm	(59")

Turntable

Diameter	124 cm	(48")
Maximum load capacity (evenly distributed)	750 kg	(1,600 lbs)

Sump Water Capacity

Approximately 250 litres (59 gallons)

Initial Blast Media Charge

40 to 50 kg (see installation instructions)

Electrical

Media Pump Motor 11 kW 3-phase 2 speed motor
Machine lighting 3 x 20 Watt fluorescent tubes
Control Voltage 240 Volts AC

Electrical Supply

Basic machine 415 Volts, 3-phase, 50 Hz

Water Supply

Connection 1/2" BSP

Compressed Air Supply

Connection 1" BSP

Inlet pressure to gun 5.0 to 7.0 Bar (74 to 104 psi)

Air Consumption:

Process gun fitted with 6.75 mm (17/64") diameter air jet and 12.5 mm (1/2") diameter process nozzle:

Approximately 1.5 to 1.70 m³/min (40-60 CFM)

depending on air pressure setting required for the

application. Where multiple process guns are required

for the application, a higher nominal free air volume will

be needed.

INDEX TO ILLUSTRATIONS

- 1 Roof Light
- 2 Electrical Control Box
- 3 Cabinet Door
- 4 Media Pump
- 5 Sump Overflow Outlet
- 6 Portable Wet Cyclone (Optional)
- 7 Oil Separator & Recirculating Tank (Optional)
- 8 Pump Tee Piece
- 9 Cabinet Exhaust Vent
- 10 Window Wiper
- 11 Safety Glass Window
- 12 Control Panel
- 13 Work Gloves
- 14 Knee-operated Switches
(Pump On/Air On/Pump & Air Stop)
- 15 Electrically controlled revolving Turntable
- 16 Load/Unload Station

ADAE PTY LTD TRADING AS
Dana-Ridge

ABN 93 109 483 007

HEAD OFFICE

12/67 Bancroft Road
Pinkenba QLD 4008
PO Box 2834
Ascot QLD 4007

ph. +61 (0)7 3860 4913

Australia Toll-free 1800 806 316

New Zealand Toll-free 0800 944 788

Website: www.dana-ridge.com.au

Dana-Ridge operates a policy of continuous development and reserves the right to change without notice any of the specifications of its products. All information, data and illustrations given in this leaflet are subject to variation and are intended for general guidance only.