

The MARS

A high performance wet blast machine developed especially for small and medium production use, offering:–

- Single operation cleaning – grease, oil, burnt-on carbon, paint, grime, scale ... all removed simultaneously,
- No toxic or harmful chemicals – no atmospheric or environmental pollution,
- Complete elimination of dust and heat during cleaning,
- Superior surface finishing,
- No component erosion or media impregnation – threads, bearing areas and other critical measurements maintained,
- Capable of processing all types of materials,
- Lower media and maintenance cost than conventional dry blasting.



Capacity

Inside dimensions: 105cm wide x 92cm high x 103cm deep with a manually rotated, 70cm diameter abrasive resistant turntable with a 200kg load capacity. A wide range of component profiles and dimensions can be accepted.

Visibility

Good visibility is achieved by a wide safety window with water spray and pneumatic wiper plus high density fluorescent lighting. The toughened glass provides high strength and white rubber curtains give good visibility as well as protection.

Ergonomics

The turntable aids component handling. The user-friendly process gun can be hand-held or bracket-mounted. A mains water rinse nozzle is provided.

Easy loading

A right hand door, which is fitted with a safety switch and cam-action locking handles, allows easy access.

Simple control

Control of the pump and compressed air is by foot switches. Further air control is by an air pressure regulator and gauge incorporated into the airline.

High performance

This is achieved with the purpose-designed high volume pump and matching process gun. The pump and gun are lined to give maximum protection against abrasive wear.

Versatility

The system can be used with a wide range of abrasives, glass beads or plastic media.

Low power

The pump motor is 4.0kW three phase.

GRP construction

Sound attenuation of the glass fibre reinforced plastic cabinet is nominally 85db(A). The cabinet includes waste separation and removal. Quality components ensure minimum maintenance.

Optional equipment

Sump overflow tank: This is connected to the machine overflow to trap solids which might otherwise be carried to the drains. A baffle retains floating contamination like oil and grease which can be periodically decanted off.



Closed circuit system: This is intended for installations where drainage is unavailable. Waste solids and floating contamination are removed whilst cleansed water is recirculated to the machine.

Quick change window system: only really applicable to certain applications where frequent window changes are required, this permits a quick changeover as well as cutting costs because it incorporates two windows – a safety pane and an inexpensive sacrificial one.

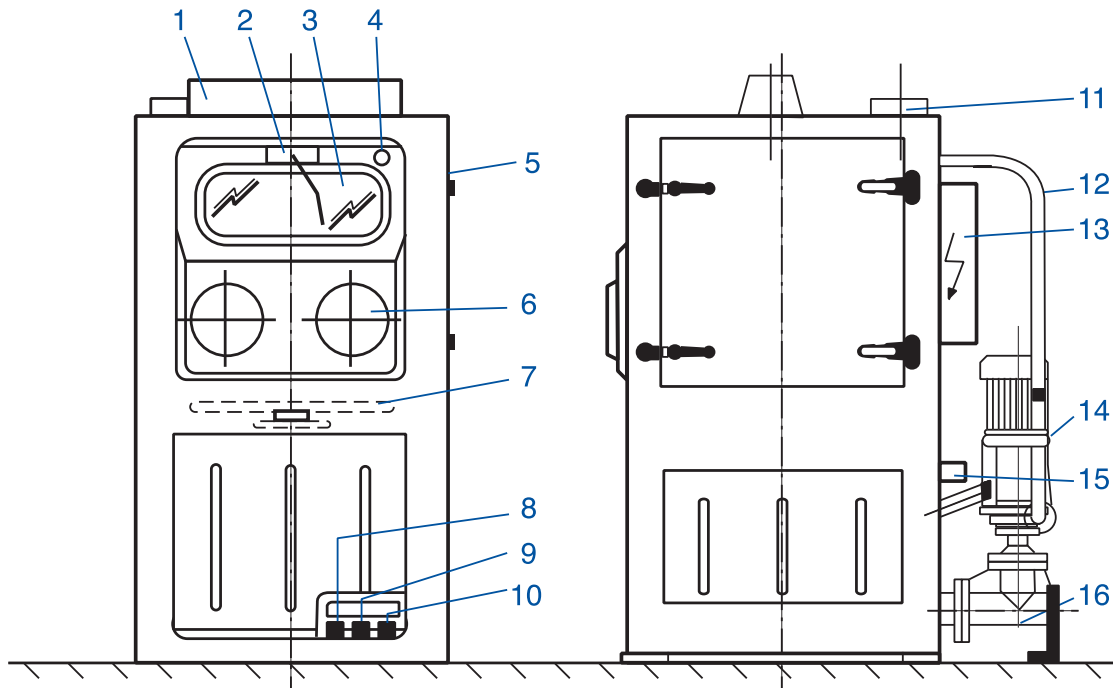

SPECIFICATIONS

External Dimensions

Height	204cm	(80")
Depth inclusive of pump unit	168cm	(66")
Width (door closed)	116cm	(46")
Width (door open)	200cm	(79")
Loading height	96cm	(38")
Working height at gloves	118cm	(46")

Internal Dimensions

Height above turntable	92cm	(36")
Depth (front to rear)	103cm	(40")
Width	105cm	(41")

Turntable

Diametre	70cm	(28")
Maximum load capacity (evenly distributed)	200kg	(440lbs)

Sump Water Capacity

Approximately 125 litres

Initial Blast Media Charge

15 to 25kg
(see installation instructions)

Electrical

Media pump motor	4kW two pole
Machine lighting	3x20Watt fluorescent tube units
Control Voltage	24 Volts AC

Electrical Supply

Basic machine 380/415 Volts, 3 phase, 50 Hz

Water Supply

Via 1/2" BSP connection

Compressed Air Supply

Connection	1/2" BSP
Inlet pressure to gun	2.1 to 5.6Bar (30 to 80p.s.i.)

Air consumption:

Process gun fitted with 4.76mm (3/16") diameter air jet and 10mm (3/8") diameter process nozzle:
Approximately 0.42 to 0.85m³/minute (15 to 35 CFM) depending on air pressure setting required for application.

INDEX TO ILLUSTRATION

- 1 Roof Light
- 2 Window Wiper
- 3 Safety Glass Window
- 4 Window Wash Valve
- 5 Cabinet Door
- 6 Work Gloves
- 7 Turntable
- 8 Foot Switch – Pump Start
- 9 Foot Switch – Air to Gun Start
- 10 Foot Switch – Pump & Air Stop
- 11 Cabinet Exhaust Vent
- 12 Media Delivery Pipework
- 13 Electrical Control
- 14 Media Pump Unit
- 15 Sump Overflow Outlet
- 16 Pump Tee Piece

ADAE PTY LTD TRADING AS
Dana-Ridge

ABN 93 109 483 007

HEAD OFFICE

12/67 Bancroft Road
Pinkenba QLD 4008
PO Box 72
Albion BC QLD 4010

ph. +61 (0)7 3860 4913

fx. +61 (0)7 3860 4869

Australia Toll-free 1800 806 316

New Zealand Toll-free 0800 944 788

Website: www.dana-ridge.com.au

Dana-Ridge operates a policy of continuous development and reserves the right to change without notice any of the specifications of our products. All information, data and illustrations given in this leaflet are subject to variation and are intended for general guidance only.