

# The MERCURY

A high performance wet blast machine developed specifically for laboratories, garages and smaller scale use in workshops and factories offering:-

- Single operation cleaning – grease, oil, burnt-on carbon, paint, grime, scale ... all removed simultaneously,
- No toxic or harmful chemicals – no atmospheric or environmental pollution,
- Complete elimination of dust and heat during cleaning,
- No component erosion or media impregnation – threads, bearing areas and other critical measurements maintained,
- Capable of processing all types of materials,
- Lower media and maintenance cost than conventional dry blasting.

## Capacity

Its compact size gives a minimum space requirement with a maximum area for component handling. Inside dimensions: 68cm wide x 62cm high x 67cm deep with a manually rotated, 50cm diameter abrasive resistant turntable with a 50kg load capacity. A wide range of component profiles and dimensions can be accepted.

## Visibility

Good visibility is achieved by a wide safety window with water spray and pneumatic wiper plus high density fluorescent lighting. The special safety film protected viewing window and white rubber curtains provides the operator with good visibility as well as protection.

## Ergonomics

The unit can be operated either standing or sitting. The turntable aids component handling. The process gun can be hand-held or bracket mounted. A mains water rinse gun is provided.

## Easy Loading

A spring-mounted swing-up top incorporates a safety switch and gives three-sided access with an 85cm loading height eliminating the space wasting swing doors.

## Simple Control

Control of the pump and compressed air is by three foot switches, providing the operator with total hands-free control of the blasting process. Additional air control is by an air pressure regulator and gauge incorporated into the airline.

## High Performance

This is achieved with the purpose designed high volume pump and matching process gun. The pump and gun are both lined to give maximum protection against abrasive wear.

## Versatility

The system can be used with a wide range of abrasives; glass beads, plastic, sodium bicarbonate, organic and other soft blast media.

## Low Power Consumption

The pump motor is a 1.5KW single phase. Compressed air consumption ranges from 0.23 to 0.73 m<sup>3</sup>/min (8-26 CFM) depending upon the speed and intensity of blasting required.

## GRP Construction

Sound attenuation of the glass fibre reinforced plastic cabinet is only 80 dB(A). The cabinet includes waste separation and removal. Quality components ensure minimum maintenance.



Turntable

## Optional Equipment

**Sump Overflow Tank:** This is connected to the machine overflow to trap solids that might otherwise be carried to drains. A baffle retains floating contamination like oil and grease that can be periodically decanted off.

**Closed Circuit System:** This is intended for installations where drainage is unavailable. Waste solids and floating contamination are removed whilst cleansed water is recirculated to the machine.

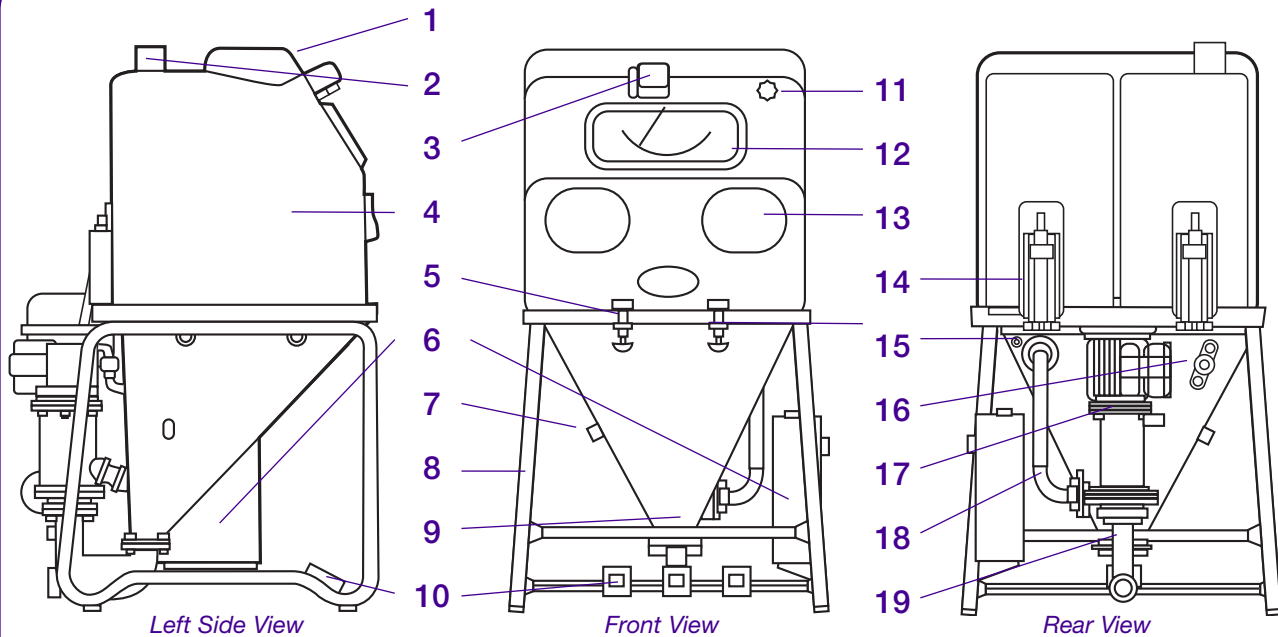

## SPECIFICATIONS

### External Dimensions

Overall Height	176cm	(69")
Depth inclusive of pump unit	102cm	(40")
Width	91cm	(36")
Loading Height	102cm	(40")
Working Height at Gloves	127cm	(50")

### Internal Dimensions

Height above Turntable	62cm	(24")
Depth (front to rear)	67cm	(26")
Width	68cm	(27")

### Turntable

Diameter	50cm	(20")
Maximum Load Capacity (evenly distributed)	50 kg	(110 lbs)

### Sump Water Capacity

Approximately 26 litres

### Initial Blast Media Charge

2 to 4.5 kg  
(see installation instructions)

### Electrical

Media Pump Motor	1.5kW two pole
Machine lighting	2 x 20 Watt fluorescent tube units
Control Voltage	24 Volts AC

### Electrical Supply

Basic machine 240 Volts, single phase, 50 Hz

### Water Supply

Connection 1/2" BSP

### Compressed Air Supply

Connection 1/2" BSP

Inlet pressure to gun 2.1 to 5.6 Bar (30 to 80 psi)

Air Consumption:

Process gun fitted with 4.76mm (3/16") diameter air jet and 10 mm (3/8") diameter process nozzle:

Approximately 0.23 to 0.73 m<sup>3</sup>/min (8-26 CFM)

depending on air pressure setting required for application.

## INDEX TO ILLUSTRATIONS

1	Roof Light Cover
2	Exhaust Vent
3	Window Wiper Assembly
4	Machine Lid
5	Lid Catch Assembly
6	Electrical Control Panel
7	Sump Overflow Outlet
8	Sump Mounting Frame
9	Machine Sump
10	Start/Air On/Stop Foot Switches
11	Window Wash Valve
12	Viewing Window
13	Work Gloves
14	Lid Return Springs
15	Compressed Air Connection
16	Water Connection
17	Media Pump Unit
18	Media Delivery Hose
19	Sump J-Bend Assembly

ADAE PTY LTD TRADING AS  
**Dana-Ridge**

ABN 93 109 483 007

### HEAD OFFICE

12/67 Bancroft Road  
Pinkenba QLD 4008  
PO Box 72  
Albion BC QLD 4010

ph. +61 (0)7 3860 4913

fx. +61 (0)7 3860 4869

**Australia Toll-free 1800 806 316**

**New Zealand Toll-free 0800 944 788**

Website: [www.dana-ridge.com.au](http://www.dana-ridge.com.au)

Dana-Ridge operates a policy of continuous development and reserves the right to change without notice any of the specifications of its products. All information, data and illustrations given in this leaflet are subject to variation and are intended for general guidance only.